

Sinmag  
Europe

TWINO



Maitrise de l'échauffement de la pâte.  
Mastering dough heating.  
Beheersing van de deegopwarming.



Pétrissage très doux.  
Most gentle kneading process.  
Zeer zacht kneedproces.



Jusqu'à 100 % d'hydratation.  
Up to 100 % dough hydration.  
Tot 100 % deeghydratie.



Modèle de table ergonomique et robuste.  
Ergonomic and robust table model.  
Ergonomisch en robuust tafelmodel.



Pétrin à bras plongeurs  
Twin arm mixer  
Twee-armige kneder

- Capot plastique transparent avec amortisseur.
- Transparent plastic cover with gas spring.
- Transparante kunststof kap met demper.

- Moteur silencieux.
- Transmission par courroie.
- Low noise motor.
- Belt drive transmission.
- Geluidsarme motor.
- Transmissie met riemaandrijving.

- Commande digitale simple d'utilisation.
- Easy digital control panel.
- Eenvoudig digitaal paneel.

- Minuterie avec 5 vitesses et 10 étapes réglables.
- Timer with 5 speeds and 10 adjustable mixing steps.
- Timer met 5 snelheden en 10 instelbare stappen.

- Bras de pétrissage en Inox démontables sans outils.
- Adapté pour lave-vaisselle.
- Stainless steel kneading arms easily removable without tools.
- Dishwasher safe.
- RVS kneedarmen, demonteerbaar zonder werktuigen.
- Vaatwasbestendig.



**TWINO 12**

- Sur des roulettes pivotantes.
- On swivel wheels.
- Op zwenkwiel'tjes.

**6** -> 400 mm  
**12** -> 460 mm

**6** -> 545 mm  
**12** -> 690 mm

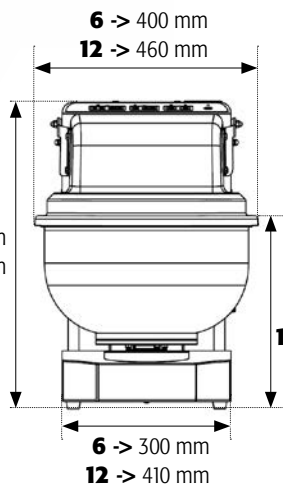

**6** -> 830 mm  
**12** -> 1020 mm

**6** -> 330 mm  
**12** -> 450 mm

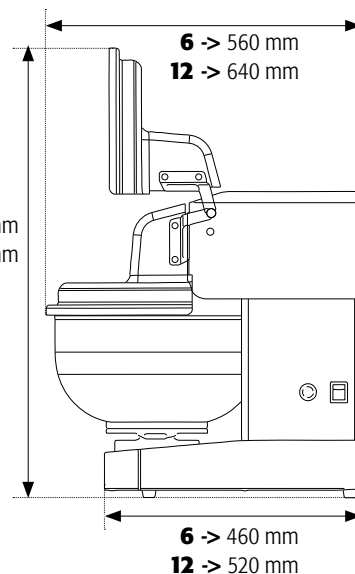

**6** -> 560 mm  
**12** -> 640 mm

**6** -> 460 mm  
**12** -> 520 mm

**TWINO**

	<b>6</b>	<b>12</b>
Capacité pâte    Dough capacity    Deegcapaciteit	1,5 - 6 kg	3 - 12 kg
Capacité farine    Flour capacity    Bloemcapaciteit	1 - 4 kg	2 - 8 kg
Coulage    Liquid    Vloeistof	0,5 - 2 L	1 - 4 L
Capacité cuve    Bowl capacity    Kuipinhoud	16 L	32 L
Rotation des bras    Arm rotations    Armomwentelingen	35 - 65 /min	35 - 65 /min
Poids net machine    Net weight machine    Nettogewicht machine	49 kg	88 kg
Puissance moteur    Motor power    Motorvermogen	750 W	1500 W
Voltage    Voltage    Spanning	230V 50Hz 1Ph	230V 50Hz 1Ph