

**Modular Cooking Range Line
 thermaline 90 - 4 Zone Electric Solid
 Top on Warming Cabinet, 2 Sides-
 Ecotop H=800**

ITEM # _____

MODEL # _____

NAME # _____

SIS # _____

AIA # _____



589706 (MCLSFCJ4AO) Electric Solid Top, 4 zones, ecoTop coating, two-side operated, on Warming Cabinet

Short Form Specification

Item No. _____

Unit constructed according to DIN 18860_2 with 20 mm drop nose top and 70 mm recessed plinth. Internal frame for heavy duty sturdiness in stainless steel. 2 mm top in 1.4301 (AISI 304). Flat surface construction, easily cleanable. THERMODUL connection system enables seamless worktop when units are connected and avoids soil penetrating. ECOTOP model with a 20 mm thick steel cooking surface with heat retaining coating. 4 independently controlled heating zones with 2 electronic sensors per zone for temperature surface control and 8 power levels. Rapid plate heat up, continuously ready to use. Overheat protection switches off the supply in case of overheating. Standby function saves energy and quickly recovers maximum power. Metal knobs with embedded hygienic silicon "soft" grip enable easier handling and cleaning. 1000 mm wide passthrough warming cabinet with 4 doors, constructed according to DIN 18860_2 with 70 mm recessed plinth. Internal frame for heavy duty sturdiness in stainless steel. Temperature in the cabinet can be set through thermostat, up to a maximum of 110 °C. Cabinet storage space accepts GN 1/1 containers. IPX5 water resistant certification.

Main Features

- 4 heating zones independently controlled.
- Rapid heat up of the plate and continuously ready for use.
- Overheat protection: a temperature sensor switches off the supply in case of overheating.
- Pans can easily be moved from one area to another without lifting.
- Wide rounded cleaning zone around the plates for easier cleaning.
- All major components may be easily accessed from the front.
- THERMODUL connection system creates a seamless work top when units are connected to each other thus avoiding soil penetrating vital components and facilitating the removal of units in case of replacement or service.
- Metal knobs with embedded hygienic silicon "soft" grip for easier handling and cleaning. The special design of the controls prevent infiltration of liquids or soil into vital components.
- Cooking plate and base joint profile guarantee against soil infiltration.
- Two electronic sensors per zone to control surface temperature and to protect cooking plate from overheating.
- 8 power levels.
- Large visible digital display manufactured in tempered glass to resist heat and chemicals, showing temperatures or power settings. The display also shows on/off status of the appliance and on/off status of the heating elements.
- Unit constructed according to DIN 18860_2 with 70 mm recessed plinth.
- Temperature in the cupboard can be set through a thermostat to suit different requirements. The maximum temperature is 110°C.
- ECOTOP model has a 20 mm thick steel DIN 1.7335 nickel coated cooking surface.

Construction

- 2 mm top in 1.4301 (AISI 304).
- Flat surface construction with minimal hidden areas to easily clean all surfaces
- Unit constructed according to DIN 18860_2 with 20 mm drop nose top.
- Unit constructed according to DIN 18860_2 with 20 mm drop nose top and 70 mm recessed plinth.
- IPX5 water resistance certification.
- Storage space in the base of the appliance accepts GN1/1 containers.
- Internal frame for heavy duty sturdiness in stainless steel.

Sustainability



- Standby function for energy saving and fast recovery of maximum power.

Optional Accessories

APPROVAL: _____

Front

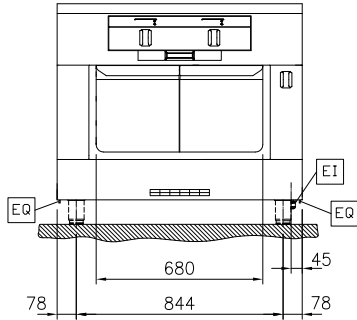

Side

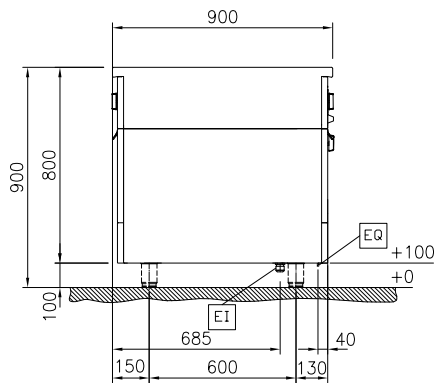

EI = Electrical inlet (power)
 EQ = Equipotential screw

Top

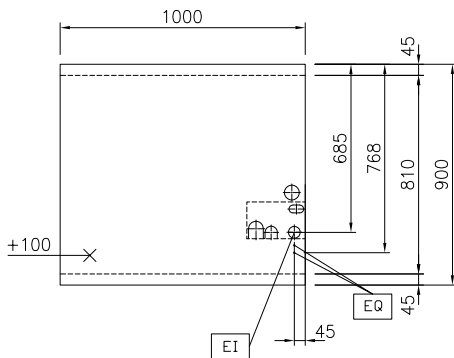
Electric
Supply voltage:

589706 (MCLSFCJ4AO) 400 V/3N ph/50/60 Hz

Electrical power max.:

18.3 kW

Key Information:
Configuration: On Oven, Both-Sides Operated

Front Plates Power: 4 - 4 kW

Back Plates Power: 4 - 4 kW

Solid top usable surface (width): 820 mm

Solid top usable surface (depth): 720 mm

External dimensions, Width: 1000 mm

External dimensions, Depth: 900 mm

External dimensions, Height: 800 mm

Net weight: 197 kg

Sustainability
Current consumption: 39.1 Amps