

## Modular Cooking Range Line thermaline 90 - Electric Bain Marie Top, 1/1GN, Left Tap, 1 Side

ITEM # \_\_\_\_\_

MODEL # \_\_\_\_\_

NAME # \_\_\_\_\_

SIS # \_\_\_\_\_

AIA # \_\_\_\_\_

**589633 (MCBFAEAOAO)**

 Electric Bain-marie Top with  
 left tap, one-side operated,  
 1/1 GN

### Short Form Specification

#### Item No.

Unit constructed according to DIN 18860\_2 with 20 mm drop nose top. Internal frame for heavy duty sturdiness in stainless steel. 2 mm top in 1.4301 (AISI 304). Flat surface construction, easily cleanable. THERMODUL connection system enables seamless worktop when units are connected and avoids soil penetrating. Water basin in 1.4435 (AISI 316L) stainless steel, seamlessly welded into the top of the appliance. Water temperature regulated by sensors. Safety systems and automatic low-water level shut-off protect against overheating. All-round basin raised edges to protect against soil infiltration. Metal knobs with embedded hygienic silicon "soft" grip enable easier handling and cleaning. IPX5 water resistance certification.

Configuration: One-side operated top with left mixing tap. The base needs to be supplied by the factory. Please include appropriate base.

### Main Features

- Filling water level is plate-marked on the side of the well.
- Overheat protection: a temperature sensor switches off the supply in case of overheating.
- Easy to clean basin with rounded corners.
- THERMODUL connection system creates a seamless work top when units are connected to each other thus avoiding soil penetrating vital components and facilitating the removal of units in case of replacement or service.
- Metal knobs with embedded hygienic silicon "soft" grip for easier handling and cleaning. The special design of the controls prevent infiltration of liquids or soil into vital components.
- Large visible digital display manufactured in tempered glass to resist heat and chemicals, showing temperatures or power settings. The display also shows on/off status of the appliance and on/off status of the heating elements.
- Raised edge all around the well to protect from infiltration of dirt from worktop.
- Water temperature controlled by electronic sensor and can be selected as either temperature or power levels.
- Safety systems protect against overtemperature and can be manually reset.

### Construction

- 2 mm top in 1.4301 (AISI 304).
- Flat surface construction with minimal hidden areas to easily clean all surfaces
- Internal frame for heavy duty sturdiness in 1.4301 (AISI 304).
- Water basin in 1.4435 (AISI 316L) stainless steel is seamlessly welded into the top of the appliance.
- IPX5 water resistance certification.
- Unit constructed according to DIN 18860\_2 with 20 mm drop nose top.
- Unit constructed according to DIN 18860\_2 with 20 mm drop nose top and 70 mm recessed plinth.

### Sustainability



- Standby function for energy saving and fast recovery of maximum power.

APPROVAL: \_\_\_\_\_

## Modular Cooking Range Line thermaline 90 - Electric Bain Marie Top, 1/1GN, Left Tap, 1 Side

Front

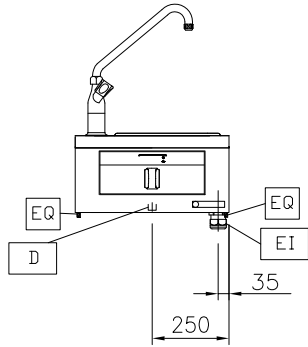

Side

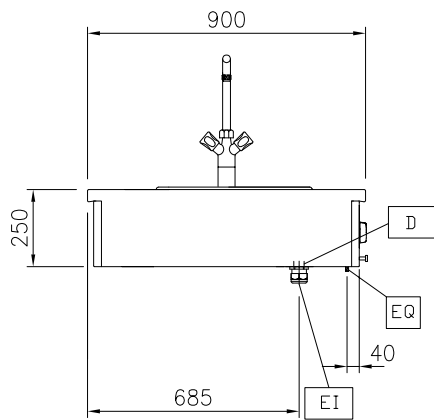

- D = Drain  
 DO = Overflow drain pipe  
 EI = Electrical inlet (power)  
 EQ = Equipotential screw  
 WI = Water inlet

Top

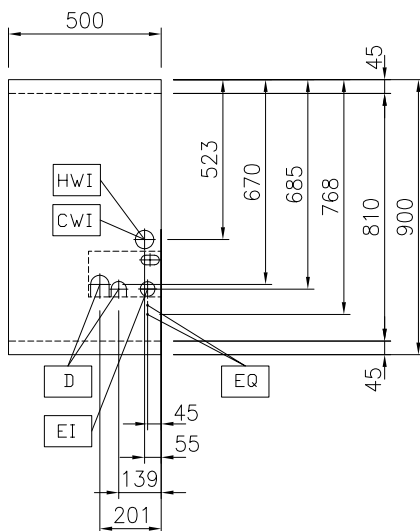

### Electric

#### Supply voltage:

589633 (MCBFAAE0AO) 400 V/3N ph/50/60 Hz

#### Total Watts:

1.5 kW

### Water:

#### Inlet water line size:

3/4"

#### Incoming Cold/hot Water line size:

3/4"

#### Drain line size:

1"

### Key Information:

#### Configuration:

One-Side Operated; Top

#### Number of wells:

1

#### Usable well dimensions (width):

307 mm

#### Usable well dimensions (height):

170 mm

#### Usable well dimensions (depth):

509 mm

#### Well capacity:

5 lt MIN; 32 lt MAX

#### Thermostat Range:

30 °C MIN; 90 °C MAX

#### External dimensions, Width:

500 mm

#### External dimensions, Depth:

900 mm

#### External dimensions, Height:

250 mm

#### Net weight:

25 kg

### Sustainability

#### Current consumption:

3.8 Amps

### Optional Accessories

- Connecting rail kit, 900mm PNC 912502
- Portioning shelf, 500mm width PNC 912523
- Portioning shelf, 500mm width PNC 912553
- Folding shelf, 300x900mm PNC 912581
- Folding shelf, 400x900mm PNC 912582
- Fixed side shelf, 200x900mm PNC 912589
- Fixed side shelf, 300x900mm PNC 912590
- Fixed side shelf, 400x900mm PNC 912591
- Connecting rail kit: modular 90 (on the left) to ProThermetic tilting (on the right), ProThermetic stationary (on the left) to ProThermetic tilting (on the right) PNC 912975
- Connecting rail kit: modular 80 (on the right) to ProThermetic tilting (on the left), ProThermetic stationary (on the right) to ProThermetic tilting (on the left) PNC 912976
- Endrail kit, flush-fitting, left PNC 913111
- Endrail kit, flush-fitting, right PNC 913112
- Lid for aquacooker 1/1 GN and bain marie 1/1 GN PNC 913139
- Endrail kit (12.5mm) for thermaline 90 units, left PNC 913202
- Endrail kit (12.5mm) for thermaline 90 units, right PNC 913203
- T-connection rail for back-to-back installations without backsplash PNC 913227
- Insert profile d=900 PNC 913232
- Energy optimizer kit 14A - factory fitted PNC 913244
- Endrail kit, (12.5mm), for back-to-back installation, left PNC 913251
- Endrail kit, (12.5mm), for back-to-back installation, right PNC 913252
- Endrail kit, flush-fitting, for back-to-back installation, left PNC 913255
- Endrail kit, flush-fitting, for back-to-back installation, right PNC 913256
- GN DIVIDER SET FOR BAIN MARIE PNC 913297
- Adapter Container in 1/1 GN Bain Marie PNC 913657
- Filter W=500mm PNC 913664
- Electric mains switch 25A 4mm<sup>2</sup> NM for modular H800 electric units (factory fitted) PNC 913676