



**Electrolux**  
PROFESSIONAL

**Modular Cooking Range Line  
thermaline 90 - Full Module  
Freestanding Electric Fry Top, 1 Side,  
H=700**

ITEM # \_\_\_\_\_

MODEL # \_\_\_\_\_

NAME # \_\_\_\_\_

SIS # \_\_\_\_\_

AIA # \_\_\_\_\_



- 589534 (MCHBEAHDAAO)** Electric Fry Top with smooth chrome Plate, one-side operated
- 589542 (MCHDEAHDAAO)** Electric Fry Top with ribbed chrome Plate, one-side operated

**Short Form Specification**

**Item No.** \_\_\_\_\_

Unit constructed according to DIN 18860\_2 with 20 mm drop nose top and 70 mm recessed plinth. Internal frame for heavy duty sturdiness in stainless steel. 2 mm top in 1.4301 (AISI 304). Flat surface construction, easily cleanable. THERMODUL connection system enables seamless worktop when units are connected and avoids soil penetrating. Chromium-plated mild steel cooking surface with non-stick finishing for optimal grilling. Powerblock heating system for optimal temperature distribution. Large drain hole allows draining of cooking juices into a large collector. Overheat protection switches off the supply in case of overheating. Standby function saves energy and quickly recovers maximum power. Metal knobs with embedded hygienic silicon "soft" grip enable easier handling and cleaning. IPX5 water resistant certification. Configuration: Freestanding, One-side operated.

**Main Features**

- Choice of one or two heating zones. An indicator lamp shows operating state of each zone.
- Large drain hole on cooking surface permits the draining of residual cooking juices into a large collector placed under the cooking surface.
- Overheat protection: a temperature sensor switches off the supply in case of overheating.
- Stainless steel high splash guards on the rear and sides of cooking surface.
- Units have separate controls for each half module of the cooking surface.
- All major components may be easily accessed from the front.
- THERMODUL connection system creates a seamless work top when units are connected to each other thus avoiding soil penetrating vital components and facilitating the removal of units in case of replacement or service.
- Metal knobs with embedded hygienic silicon "soft" grip for easier handling and cleaning. The special design of the controls prevent infiltration of liquids or soil into vital components.
- Large visible digital display manufactured in tempered glass to resist heat and chemicals, showing temperatures or power settings. The display also shows on/off status of the appliance and on/off status of the heating elements.
- Powerblock heating system for optimal temperature distribution.

**Construction**

- 2 mm top in 1.4301 (AISI 304).
- Unit constructed according to DIN 18860\_2 with 20 mm drop nose top and 70 mm recessed plinth.
- Flat surface construction with minimal hidden areas to easily clean all surfaces
- Cooking surface in chromium-plated mild steel with non-stick finishing for optimum grilling results.
- IPX5 water resistance certification.
- Internal frame for heavy duty sturdiness in stainless steel.
- Cooking surface to be completely smooth or completely ribbed.

**Sustainability**



- Standby function for energy saving and fast recovery of maximum power.

**APPROVAL:** \_\_\_\_\_



Experience the Excellence  
[www.electroluxprofessional.com](http://www.electroluxprofessional.com)

### Optional Accessories

- |  |            |                          |   |            |                          |
|--|------------|--------------------------|---|------------|--------------------------|
| • Connecting rail kit, 900mm   | PNC 912502 | <input type="checkbox"/> | • Endrail kit, flush-fitting, for back-to-back installation, right  | PNC 913256 | <input type="checkbox"/> |
| • Stainless steel side panel, 900x700mm, freestanding  | PNC 912512 | <input type="checkbox"/> | • Side reinforced panel only in combination with side shelf, for freestanding units   | PNC 913260 | <input type="checkbox"/> |
| • Portioning shelf, 800mm width  | PNC 912526 | <input type="checkbox"/> | • Side reinforced panel only in combination with side shelf, for back-to-back installations, left   | PNC 913275 | <input type="checkbox"/> |
| • Portioning shelf, 800mm width  | PNC 912556 | <input type="checkbox"/> | • Side reinforced panel only in combination with side shelf, for back-to-back installation, right   | PNC 913276 | <input type="checkbox"/> |
| • Folding shelf, 300x900mm   | PNC 912581 | <input type="checkbox"/> | • Shelf fixation for TL80-85-90 one-side operated, TL80 two-side operated   | PNC 913281 | <input type="checkbox"/> |
| • Folding shelf, 400x900mm   | PNC 912582 | <input type="checkbox"/> | • Filter W=800mm  | PNC 913665 | <input type="checkbox"/> |
| • Fixed side shelf, 200x900mm  | PNC 912589 | <input type="checkbox"/> | • Stainless steel dividing panel, 900x700mm, (it should only be used between Electrolux Professional thermaline Modular 90 and thermaline C90)  | PNC 913672 | <input type="checkbox"/> |
| • Fixed side shelf, 300x900mm  | PNC 912590 | <input type="checkbox"/> | • Stainless steel side panel, 900x700mm, flush-fitting (it should only be used against the wall, against a niche and in between Electrolux Professional thermaline and ProThermetic appliances and external appliances - provided that these have at least the same dimensions) | PNC 913688 | <input type="checkbox"/> |
| • Fixed side shelf, 400x900mm  | PNC 912591 | <input type="checkbox"/> |   |            |                          |
| • Stainless steel front kicking strip, 800mm width   | PNC 912634 | <input type="checkbox"/> |   |            |                          |
| • Stainless steel side kicking strip left and right, freestanding, 900mm width   | PNC 912657 | <input type="checkbox"/> |   |            |                          |
| • Stainless steel side kicking strip left and right, back-to-back, 1810mm width  | PNC 912663 | <input type="checkbox"/> |   |            |                          |
| • Stainless steel plinth, freestanding, 800mm width  | PNC 912958 | <input type="checkbox"/> |   |            |                          |
| • Connecting rail kit: modular 90 (on the left) to ProThermetic tilting (on the right), ProThermetic stationary (on the left) to ProThermetic tilting (on the right) | PNC 912975 | <input type="checkbox"/> |   |            |                          |
| • Connecting rail kit: modular 80 (on the right) to ProThermetic tilting (on the left), ProThermetic stationary (on the right) to ProThermetic tilting (on the left) | PNC 912976 | <input type="checkbox"/> |   |            |                          |
| • Endrail kit, flush-fitting, left   | PNC 913111 | <input type="checkbox"/> |   |            |                          |
| • Endrail kit, flush-fitting, right  | PNC 913112 | <input type="checkbox"/> |   |            |                          |
| • Scraper for smooth plates (only for 589534)  | PNC 913119 | <input type="checkbox"/> |   |            |                          |
| • Scraper for ribbed plates (only for 589542)  | PNC 913120 | <input type="checkbox"/> |   |            |                          |
| • Endrail kit (12.5mm) for thermaline 90 units, left   | PNC 913202 | <input type="checkbox"/> |   |            |                          |
| • Endrail kit (12.5mm) for thermaline 90 units, right  | PNC 913203 | <input type="checkbox"/> |   |            |                          |
| • Stainless steel side panel, left, H=700  | PNC 913222 | <input type="checkbox"/> |   |            |                          |
| • Stainless steel side panel, right, H=700   | PNC 913223 | <input type="checkbox"/> |   |            |                          |
| • T-connection rail for back-to-back installations without backsplash  | PNC 913227 | <input type="checkbox"/> |   |            |                          |
| • Insert profile d=900   | PNC 913232 | <input type="checkbox"/> |   |            |                          |
| • Perforated shelf for warming cabinets and cupboard bases (one-side operated TL80-85-90 and two-side operated for TL80)   | PNC 913234 | <input type="checkbox"/> |   |            |                          |
| • Energy optimizer kit 24A - factory fitted  | PNC 913246 | <input type="checkbox"/> |   |            |                          |
| • Endrail kit, (12.5mm), for back-to-back installation, left   | PNC 913251 | <input type="checkbox"/> |   |            |                          |
| • Endrail kit, (12.5mm), for back-to-back installation, right  | PNC 913252 | <input type="checkbox"/> |   |            |                          |
| • Endrail kit, flush-fitting, for back-to-back installation, left  | PNC 913255 | <input type="checkbox"/> |   |            |                          |

### Recommended Detergents

- C41 HI-TEMP RAPID DEGREASER, 1 pack of six 1 lt. bottles (trigger incl.) PNC 0S2292



## Electric

**Supply voltage:**

589534 (MCHBEAHDAAO) 400 V/3N ph/50/60 Hz

589542 (MCHDEAHDAAO) 400 V/3N ph/50/60 Hz

**Total Watts:** 15.3 kW

## Key Information:

<b>Configuration:</b>	On Base;One-Side Operated
<b>Cooking Surface Depth:</b>	615 mm
<b>Cooking Surface Width:</b>	700 mm
<b>Working Temperature MIN:</b>	80 °C
<b>Working Temperature MAX:</b>	280 °C
<b>External dimensions, Width:</b>	800 mm
<b>External dimensions, Depth:</b>	900 mm
<b>External dimensions, Height:</b>	700 mm
<b>Storage Cavity Dimensions (width):</b>	580 mm
<b>Storage Cavity Dimensions (height):</b>	330 mm
<b>Storage Cavity Dimensions (depth):</b>	740 mm
<b>Net weight:</b>	150 kg
<b>Cooking surface type:</b>	
589534 (MCHBEAHDAAO)	Smooth
589542 (MCHDEAHDAAO)	Ribbed
<b>Cooking surface - material:</b>	Chromium Plated mild steel mirror

## Sustainability

**Current consumption:** 22.1 Amps

Front

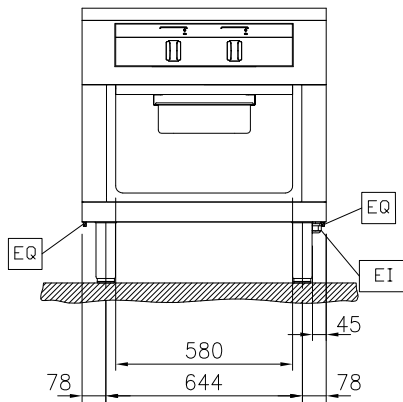

Front

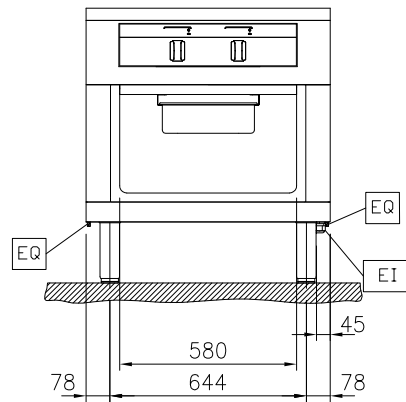

Side

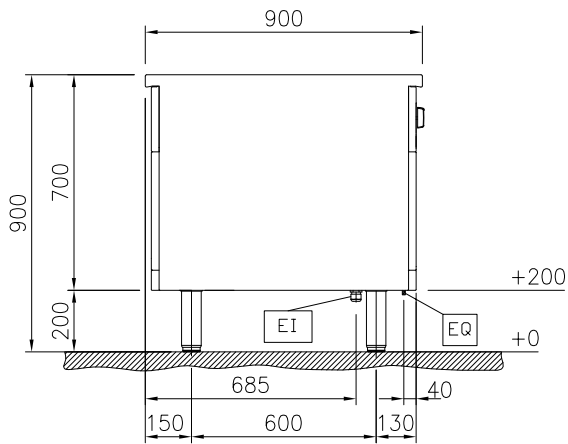

Side

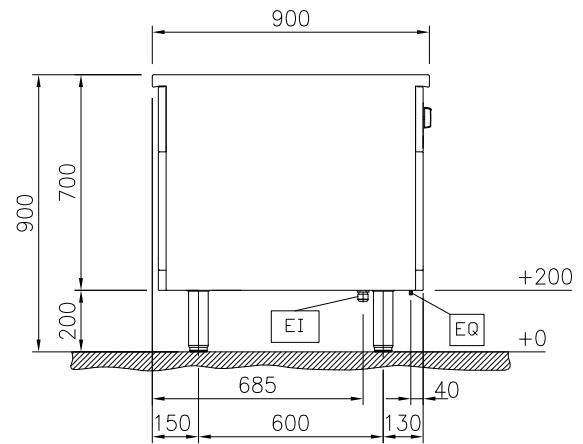

EI = Electrical inlet (power)  
 EQ = Equipotential screw

EI = Electrical inlet (power)  
 EQ = Equipotential screw

Top

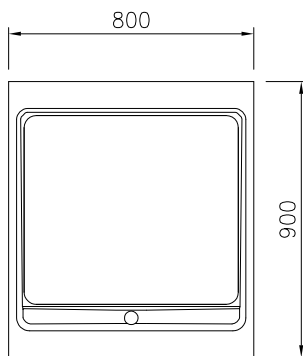

Top

