



Electrolux
PROFESSIONAL

**Modular Cooking Range Line
thermaline 90 - 600 mm Electric
Warming Cabinet with 1 door, GN
conform, 1 Side (H2) - H=450**

ITEM # _____

MODEL # _____

NAME # _____

SIS # _____

AIA # _____



589480 (MC4GCAFOAO)

Electric Warming Cabinet,
with 1 door, one-side
operated, GN - H2

Short Form Specification

Item No. _____

600 mm wide warming cabinet with 1 door. Internal frame for heavy duty sturdiness in stainless steel. Flat surface construction, easily cleanable. Temperature in the cabinet can be set through thermostat, up to a maximum of 110 °C. Cabinet storage space accepts GN 1/1 containers.

IPX5 water resistant certification.

Configuration: One-side operated freestanding base, hygienic class H2.

Main Features

- All major components may be easily accessed from the front.
- THERMODUL connection system creates a seamless work top when units are connected to each other thus avoiding soil penetrating vital components and facilitating the removal of units in case of replacement or service.
- Unit constructed according to DIN 18860_2 with 70 mm recessed plinth.
- Temperature in the cupboard can be set through a thermostat to suit different requirements. The maximum temperature is 110°C.
- Unit can be installed below modular top appliances, designed to keep plates warm.

Construction

- IPX5 water resistance certification.
- 2 mm top in 1.4301 (AISI 304).
- Flat surface construction with minimal hidden areas to easily clean all surfaces
- Storage space in the base of the appliance accepts GN1/1 containers.
- Internal frame for heavy duty sturdiness in stainless steel.

APPROVAL: _____



Experience the Excellence
www.electroluxprofessional.com

Front

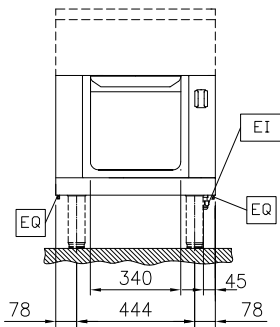

Side

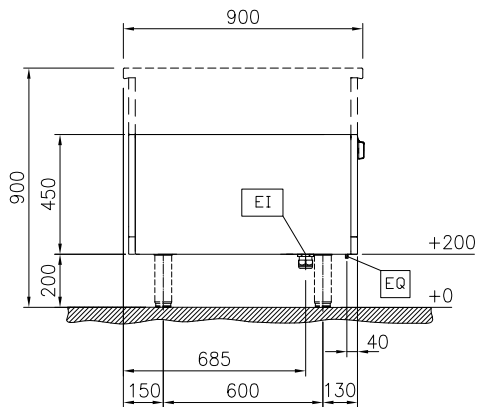

EI = Electrical inlet (power)

Top

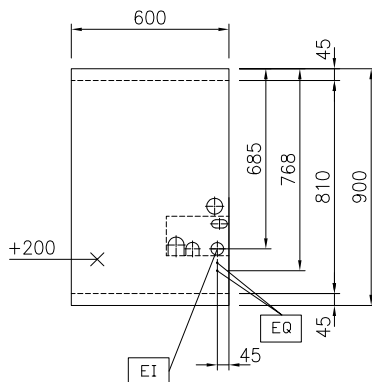
Key Information:

External dimensions, Width:	600 mm
External dimensions, Depth:	900 mm
External dimensions, Height:	450 mm
Cupboard Cavity Dimensions (width):	340 mm
Cupboard Cavity Dimensions (height):	330 mm
Cupboard Cavity Dimensions (depth):	715 mm
Cabinet temperature range:	30-110 °C
Net weight:	24 kg

Sustainability
Current consumption:

589480 (MC4GCAFOAO) 2.5 Amps

Optional Accessories

- Stainless steel side panel, 900x700mm, freestanding PNC 912512
 - Stainless steel front kicking strip, 600mm width PNC 912632
 - Stainless steel side kicking strip left and right, freestanding, 900mm width PNC 912657
 - Stainless steel side kicking strips left and right, against the wall, 900mm width PNC 912660
 - Stainless steel side kicking strip left and right, back-to-back, 1810mm width PNC 912663
 - Stainless steel plinth, against wall, 600mm width PNC 912937
 - Stainless steel plinth, freestanding, 600mm width PNC 912956
 - Stainless steel panel, 900x700mm, against wall, left side PNC 913101
 - Stainless steel panel, 900x700mm, against wall, right side PNC 913105
 - Back panel, 600x450mm, for bases one-side operated PNC 913165
 - Stainless steel side panel, left, H=700 PNC 913222
 - Stainless steel side panel, right, H=700 PNC 913223
 - Perforated shelf for warming cabinets and cupboard bases (one-side operated TL80-85-90 and two-side operated for TL80) PNC 913233
 - Energy optimizer kit 14A - factory fitted PNC 913244
 - Side reinforced panel only in combination with side shelf, for freestanding units PNC 913260
 - Side reinforced panel only in combination with side shelf, for against the wall installations, left PNC 913267
 - Side reinforced panel only in combination with side shelf, for against the wall installations, right PNC 913269
 - Side reinforced panel only in combination with side shelf, for back-to-back installations, left PNC 913275
 - Side reinforced panel only in combination with side shelf, for back-to-back installation, right PNC 913276
 - Shelf fixation for TL80-85-90 one-side operated, TL80 two-side operated PNC 913279
 - Stainless steel dividing panel, 900x700mm, (it should only be used between Electrolux Professional thermaline Modular 90 and thermaline C90) PNC 913672
- Stainless steel side panel, 900x700mm, flush-fitting (it should only be used against the wall, against a niche and in between Electrolux Professional thermaline and ProThermetic appliances and external appliances - provided that these have at least the same dimensions) PNC 913688